

NOTES:

1. BASE OF CHLORINATOR TO BE EVEN OR LOWER THAT BASE OF BIO-SECTION.
2. SECURE TANKS' BASE STANDS ON A FLAT DECK OR BUILT UP FLAT SURFACE.
3. DO NOT COMBINE BIO-SECTION VENT WITH ANY OTHER VENT.
4. VENT TO TERMINATE NOT LESS THAN 10 FEET ABOVE WEATHER DECK, FROM ANY SOURCE OF IGNITION AND FROM ANY VENTILATION AIR INLET.
5. VENT TO TERMINATE HIGH RATHER THAN LOW, SINCE VENTED AIR IS WARMER THAN SURROUNDING AIR AND WILL RISE.
6. FLAME SCREEN IS NOT RECOMMENDED. IT WILL PLUG UP WITH LINT AND REQUIRE FREQUENT CLEANING. IF A FLAME SCREEN MUST BE USED, SCREEN TO BE TWO PIPE SIZES LARGER THAN VENT PIPE.
7. CONNECTING PIPING AND STANDARD PLUMBING PRACTICES AND INSTALLATION SHALL BE IN ACCORDANCE WITH REQUIREMENTS OF APPLICABLE REGULATORY BODIES.
8. FLEX OR HOSE CONNECTIONS RECOMMENDED FOR HOOK UP TO BIO-SECTION AND CHLORINATOR TO RELIEVE STRESS ON TANKS.
9. RECOMMENDED DISTANCE FROM CENTER OF BIO-SECTION TO CENTER OF CHLORINATOR IS 40".

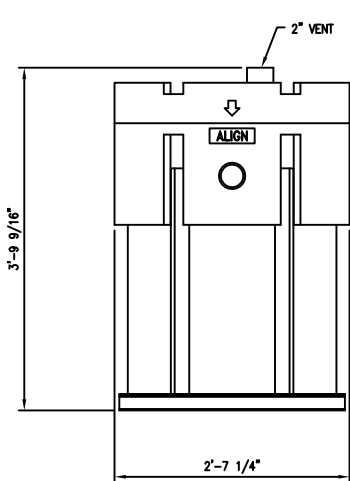

DISCHARGE VIEW

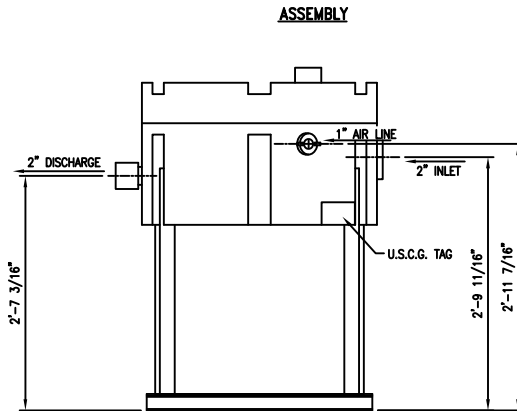

ELEVATION

BIO-SECTION
EST. WT.: 90 LBS. DRY
EST. WT.: 540 LBS OPERATING

NOTE:
WHEN BIO-SECTION IS FULLY ASSEMBLED, THE ARROW, ON THE LID, AND TEXT "ALIGN", ON THE DISCHARGE SIDE, SHOULD LINE UP ONE ON TOP OF THE OTHER.

SEAHORSE MANUFACTURING L.L.C.

5802 PARADISE LANE
LYDIA, LOUISIANA 70560
PHONE: 337-365-9115
MOBILE: 337-389-3482

P.O. BOX 516
LYDIA, LOUISIANA 70569
PHONE: 337-365-9115
MOBILE: 337-389-3482

NO.	DATE	DESCRIPTION	DRAWN BY	CLIENT
1	7/25/04	ISSUED FOR APPROVAL	SJC	TITLE
2	8/28/05	ISSUED FOR CONSTRUCTION	SJC	PROJECT
				ASSEMBLY
				SMSD-200R
DRAWN BY: SJC		DATE DRAWN: 03/25/06		SMSD-200R-03 DRAWING NUMBER
SCALE: NTS		APPROVED BY:		

